

1 A B C D E D E

2

3

4

5

6

7

8

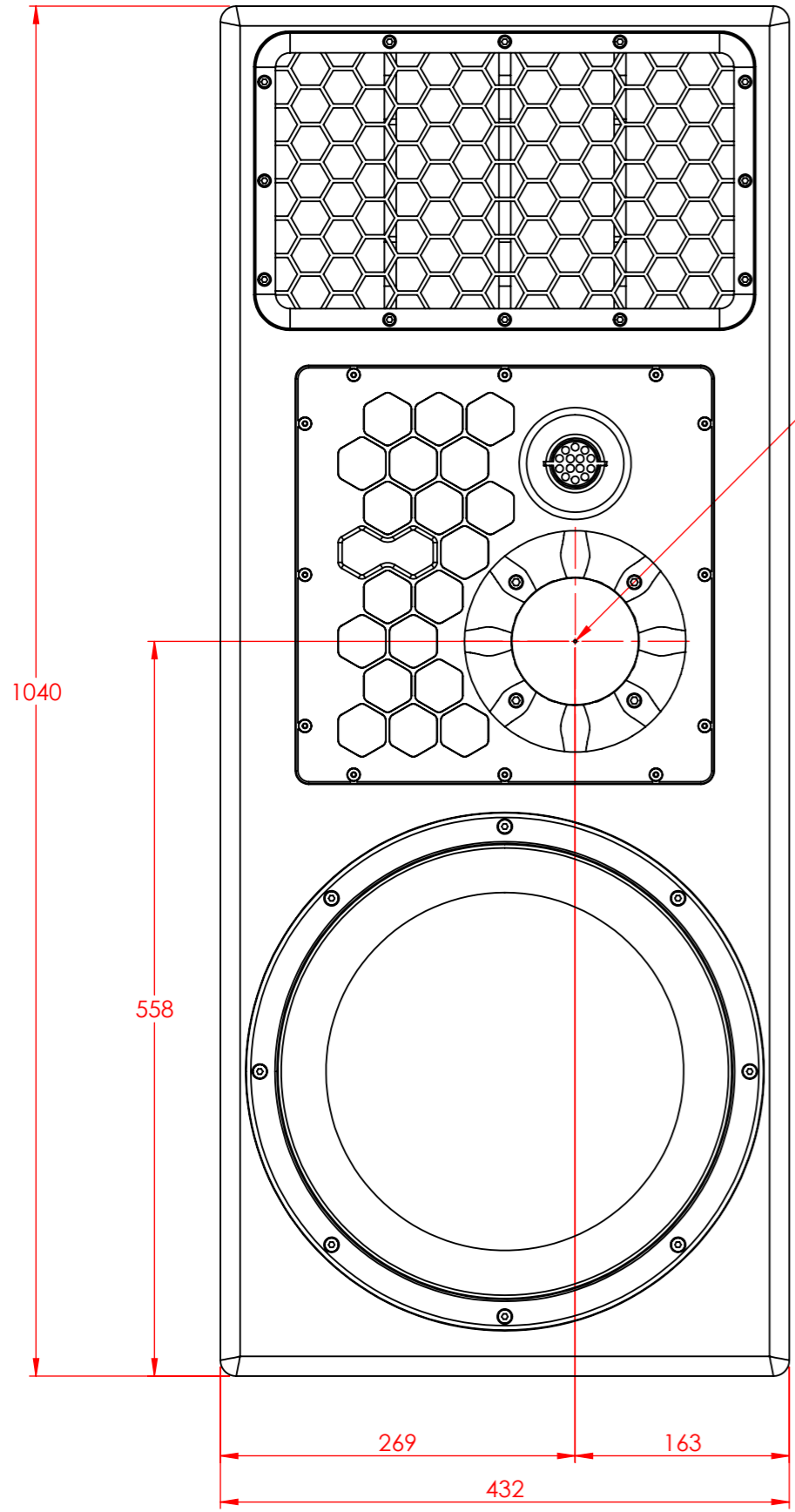

ACOUSTIC CENTRE
(LEFT-HAND CABINET
SHOWN)

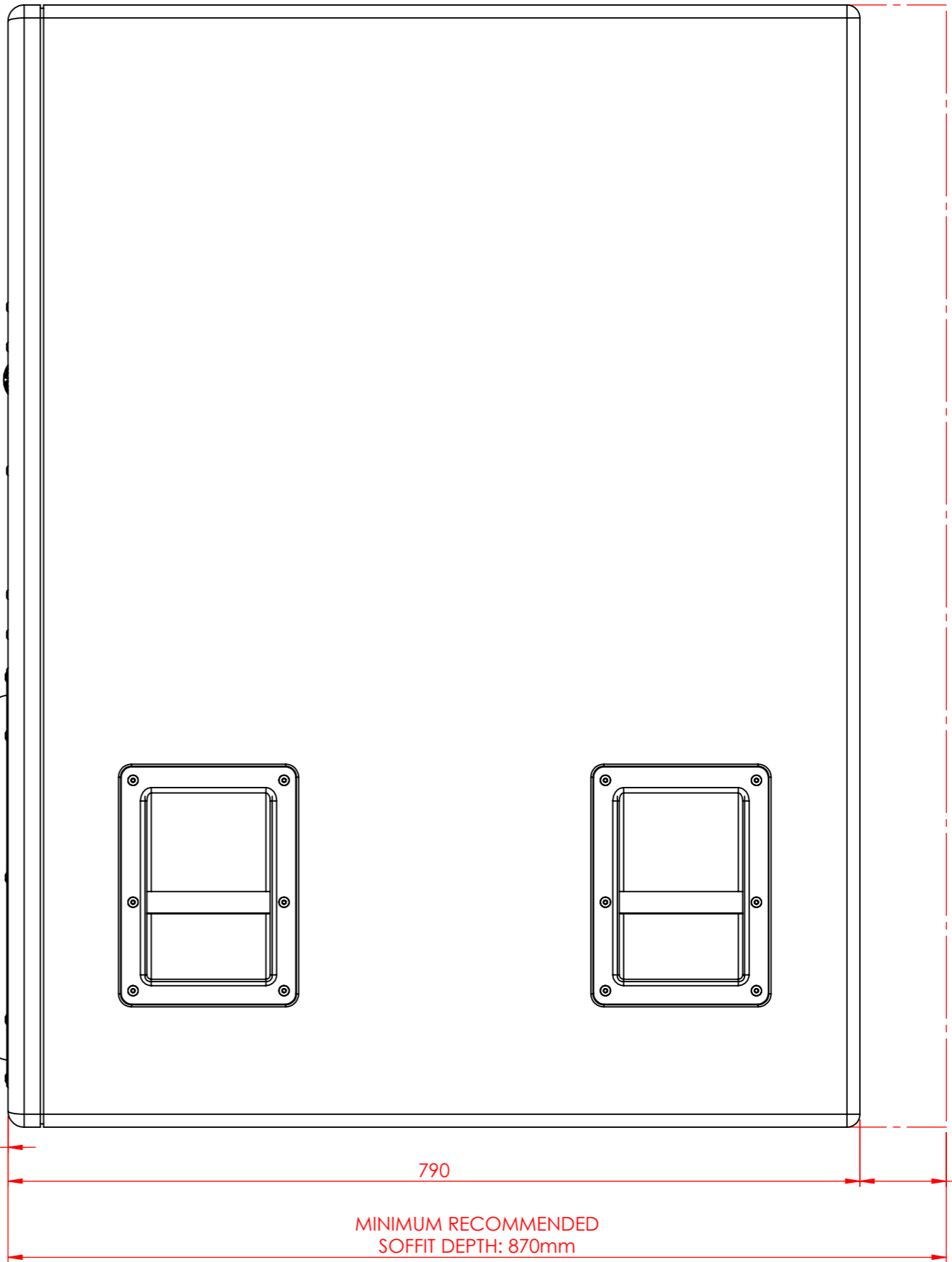

PRODUCT DIMENSIONS IDENTICAL FOR PMC15 SUB and SUBxbd
 PRODUCT WEIGHT: 97kg (Master) / 87kg (SUB or SUBxbd)
 PACKAGED WEIGHT: 139kg (Master) / 129kg (SUB or SUBxbd)
 PACKAGED DIMENSIONS: 1075 x 669 x 1176 mm (HxWxD)

PMC[®]
 THE PROFESSIONAL MONITOR COMPANY
 Holme Court
 Biggleswade, Bedfordshire SG18 9ST
 Tel: 01767 686 300

SIZE	TITLE		5			
A3	Weights & Dims		4			
SCALE	PROJECT		3			
1:5	PART NO.	REV.	2			
SHEET	All Tolerances +/-0.2mm		1	TR	First Issue	27/10/25
1 of 1	Unless otherwise stated		ISS.	INIT.	DESCRIPTION	DATE
	All Dimensions in mm					APP.